



Regatta

May 4th – Tier 3/Opti Regatta

SAILING INSTRUCTIONS (SIs)

1 RULES

- 1.1** The regatta will be governed by: 2021-2024 Racing Rules of Sailing (RRS), prescriptions of the US Sailing Association, ISSA Procedural Rules, MISSA By-laws and District Rules, NOR and the SI's.

2 CHANGES TO SAILING INSTRUCTIONS

- 2.1** Any changes to the SI's will be posted on the Official Notice Board on techscore or orally from the Race Committee Boat.
- 2.2** Changes to a sailing instruction may be made on the water by announcement from the race committee boat.

3 SIGNALS MADE ASHORE

- 3.1** Signals made ashore will be displayed at the flag pole on the upper deck.
- 3.2** When flag AP is displayed ashore, '1 minute' is replaced with 'not less than 30 minutes' in Race Signals AP.

4 SCHEDULE OF RACES

- 4.1** Saturday, May 4th
8:30 a.m. - Arrival
9:00 a.m. - Competitor's meeting
9:30 a.m. - Harbor Launch
10:00 a.m. - 1st warning signal
No races will be started after 4:00 p.m.

5 Boat Damage/Bosun Rule

- 5.1** If 420 damage cannot be attributed to a team or teams, the repair costs will be divided evenly between all the teams competing.

6 CLASS FLAGS

6.1 The Opti class will be designated with a blue opti logo on a white background. The 420 class will be designated with a blue C420 logo on a white background.

7 RACING AREA

7.1 The Racing Area will be the waters of Lake Michigan directly off the Wilmette Harbor.

8 COURSES

8.1 The diagram(s) in the appendix show the courses for the Opti and the 420 classes.

8.2 The Opti fleet will use a triangle with 4 legs. The 420 fleet will use a W4 Windward/Leeward with a dogleg finish after passing through the gate on the final leg.

9 MARKS

9.1 Marks will be yellow and orange balls. The windward mark for both fleets will be the same orange ball. Marks 2 and 3 for the Opti Fleet will be yellow balls. The gates for the 420 fleet will be orange balls.

10 THE START

10.1 The starting line is between a staff displaying an orange flag on the race committee boat at the starboard end and a yellow ball on the port end.

10.2 The starting sequence shall be 3-minute dinghy start per RRS Appendix S

10.3 Boats whose warning signal has not been made shall avoid the starting area during the starting sequence for other races.

10.4 Code Flag "X" may be displayed for individual recalls. It is the responsibility of the yacht to make a proper start. Failure of the Race Committee to make these signals or failure of a starter on the course side to see or hear these signals shall not relieve the offending yacht from restarting and is not grounds for redress. This changes RRS 62.1(a).

10.5 For the 420 fleet, the starting following a General Recall will be run under an I Flag.

10.6 A boat that does not start within 3 minutes after her starting signal will be scored Did Not Start without a hearing. This changes RRS A5.1 and A5.2.

11 THE FINISH

11.1 For the 420 fleet the finishing line is between a staff displaying an orange flag on the race committee boat at the port end and a orange ball to the starboard of the race committee boat. For the opti fleet the

finishing line is between a staff displaying an orange flag on the race committee boat at the starboard end and a yellow ball to the port of the race committee boat.

12 PENALTY SYSTEM

- 12.1** RRS 44.1 is changed so that the Two-Turns Penalty is replaced by the One-Turn Penalty.

13 HEARING REQUESTS

- 13.1** The protest time limit is 30 minutes after the race committee dock time.

- 13.2** Hearing request forms are available from the race office at the Sheridan Shores Office

14 Coaching

- 14.1** It is the responsibility of the coaches to know the limits of their competitors and pull competitors from racing if conditions exceed their limitations.

- 14.2** Coaches shall stay clear of the racing area unless assisting competitors. Coaching should take place to leeward of the start/finish line.

15 OFFICIAL NOTICE FOR ALL TEAMS

- 15.1** Sheridan Shore Sailing School, Wilmette Harbor Club, Metropolitan Water Reclamation District and its officers, members, employees, and race committee assume and accept no responsibility for property damage to any boat or personal injury to any skipper, crew, or friends incurred while participating in this regatta, including pre-and post-race activities. It is the responsibility of the skipper, along with his/her coach, advisor, and/or parent(s) to assess the condition of his/her boat, whether or not he/she owns said boat, and its suitability for the weather expected during the race, and to decide whether to start or continue any race.

16 REGATTA CONTACTS:

- 16.1** Regatta Contact: Katie Tinder – 651-491-9994,
katie@sheridanshore.org

Appendix A

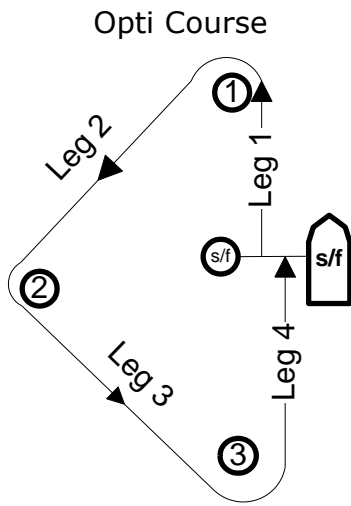

420 Course

S
F